

Open the original carton and verify the following items

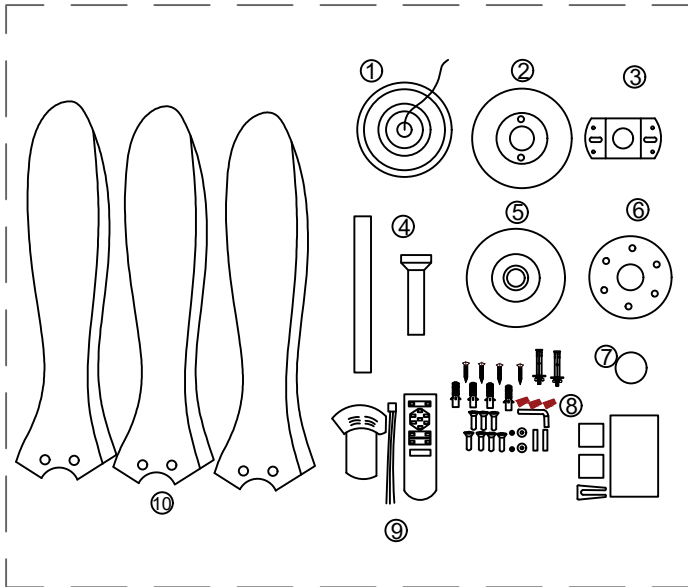

- | | |
|-----------------------|---------------------------------------|
| 1: 1 x Motor Assembly | 8: 4 x Wooden screw |
| 2: 1 x Canopy | 2 x Explosive screw |
| 3: 1 x Mounting Plate | 7 x Fan blade mounting screw |
| 4: 2 x Downrod | 1 x Balance package |
| 5: 1 x Coupling Cover | 1 x inner hexagon spanner |
| 6: 1 x Blade holder | 3 x P2 connection cap |
| 7: 1 x Bottom cover | 4 x House lizard |
| | 2 x Machine screw |
| | 2 x Spacer |
| | 9: 1 x Remote control 1 x receiver |
| | 10: 3 x Flabellum |

- 1: Align the blade screw through blade holder ring and blade with motor assembly's hole, tighten 2 screws halfway, after install all 3 blades then tighten 6 screws firmly
- 2: Screw the bottom cover into the motor shaft

